

Programmable Terminals NS-series

Best Match

- Demonstrates excellent matching with OMRON control devices. Greatly reduces the cost and effort required to connect all kinds of components, such as PLCs. Provides a wide variety of useful functional aspects of the same manufacturer.



5.7 inches
Hand-held Model



5.7 Inches



8.4 Inches



10.4 Inches



12.1 Inches

Features

- 5.7 to 12.1 inch sizes are available
- A hand-held version of the NS5 is now available to perform operations at the production site
The NS-series PT's have a complete set of functions that can be used at the production site
- The Smart Active Parts(SAP Library) makes it easy to connect to OMRON PLCs and components,
OMRON provides a development environment that requires with no programming and no screen designing
- When an error occurs in a Unit in the OMRON PLCs,
the Troubleshooter SAP Library provides an easy-to-understand explanation of the cause of the error as well as the countermeasures
- Ladder Monitor come as a Standard Feature
The ladder program can be monitored onsite without a laptop!
Ladder monitor lets you monitor PLC program status, search for addresses or instructions, monitor multiple I/O points, and much more
- Provides the FA integrated tool package "CX-One" for a Screen Design Software
Integrated Simulation come as a Standard Feature
The integrated simulation function simulates ladder programs and screen data simultaneously even without the actual hardware
- Screens support 42 languages and the Support Software supports eight
System messages can be displayed in eight languages
- Single Port Multi Access(SPMA) come as a Standard Feature
The ladder program and screen data can be transferred from a single port!
- Connectable PLCs and devices appear one after another
Has become connectable with the PLCs of Mitsubishi Electric Corporation and the Inverters of OMRON Corporation

System Configuration

NS5/NS8/NS10/NS12

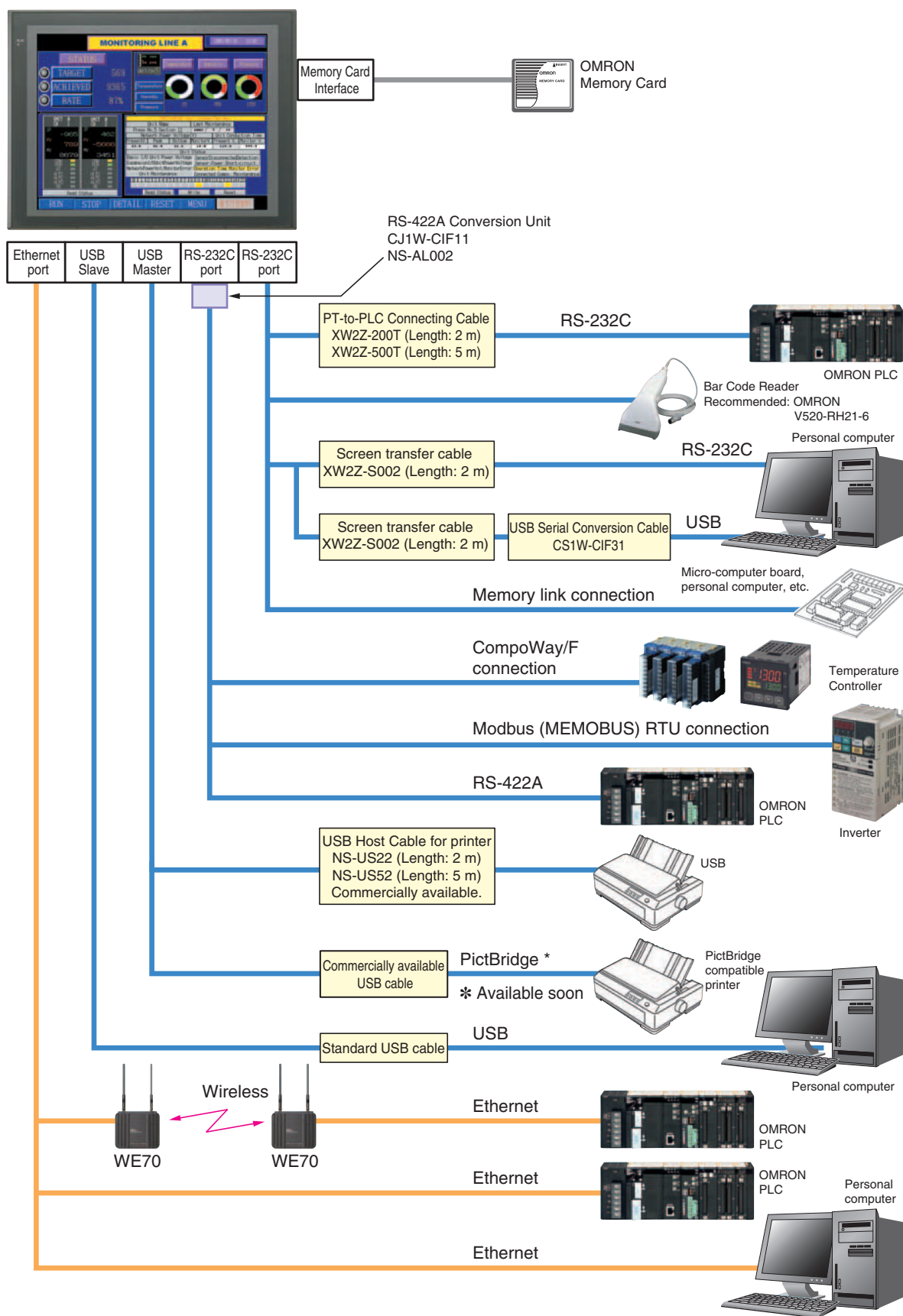

Expansion Bus Interface

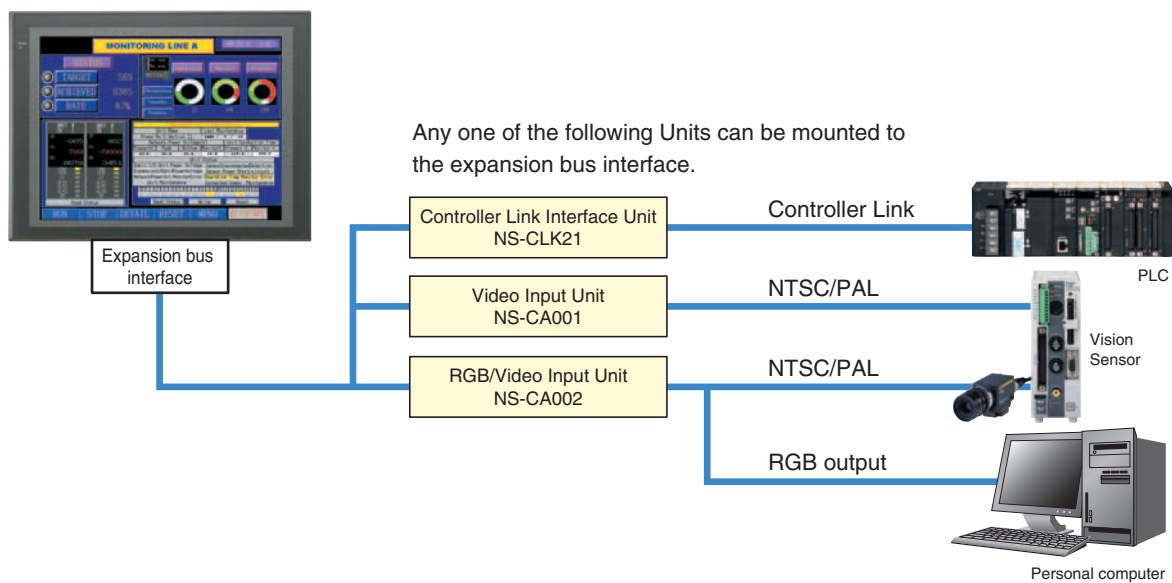

NSH5 Hand-held PT

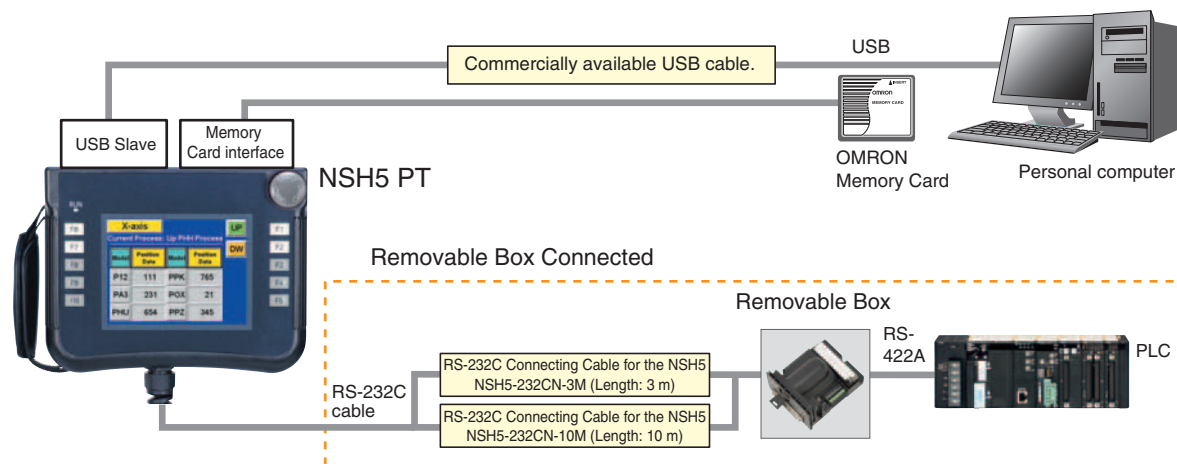
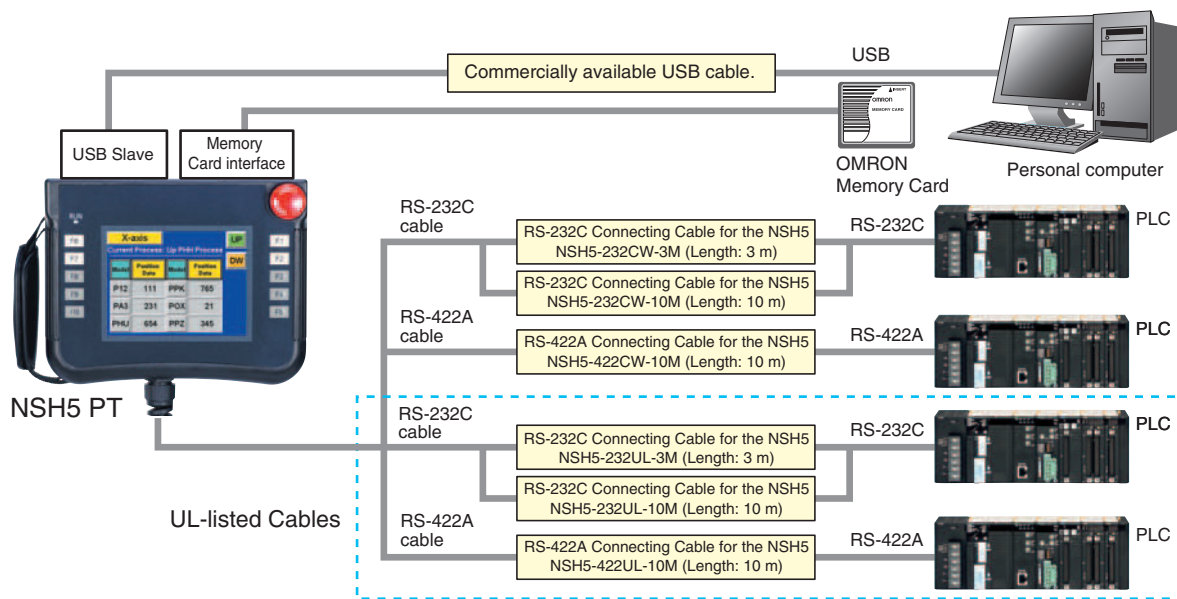

●System Configuration
(Removable Box Connected)

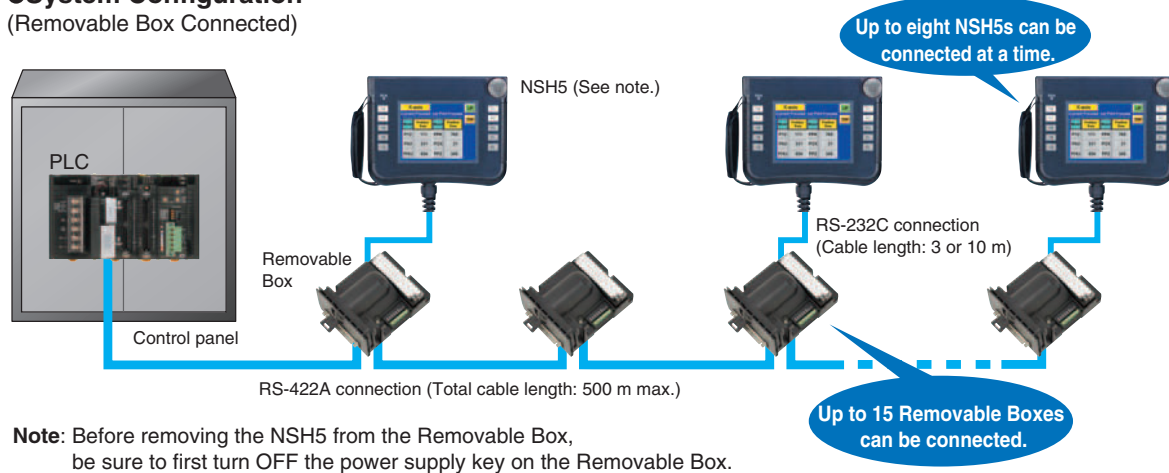

Note: Before removing the NSH5 from the Removable Box, be sure to first turn OFF the power supply key on the Removable Box.

Ordering Information

Programmable Terminals

Model name	Specifications				Model number	Standards
	Effective display area	Number of dots	Ethernet	Case color		
NS5-V2	5.7-inch STN monochrome	320 × 240 dots	No	Ivory	NS5-MQ00-V2	UC1, CE, N, L, UL Type4
				Black	NS5-MQ00B-V2	
			Yes	Ivory	NS5-MQ01-V2	
				Black	NS5-MQ01B-V2	
	5.7-inch STN		No	Ivory	NS5-SQ00-V2	
				Black	NS5-SQ00B-V2	
			Yes	Ivory	NS5-SQ01-V2	
				Black	NS5-SQ01B-V2	
	5.7-inch TFT		No	Ivory	NS5-TQ00-V2	
				Black	NS5-TQ00B-V2	
			Yes	Ivory	NS5-TQ01-V2	
				Black	NS5-TQ01B-V2	
NS8-V2	8.4-inch TFT	640 × 480 dots	No	Ivory	NS8-TV00-V2	UC1, CE, N, L
				Black	NS8-TV00B-V2	
			Yes	Ivory	NS8-TV01-V2	
				Black	NS8-TV01B-V2	
NS10-V2	10.4-inch TFT	640 × 480 dots	No	Ivory	NS10-TV00-V2	
				Black	NS10-TV00B-V2	
			Yes	Ivory	NS10-TV01-V2	
				Black	NS10-TV01B-V2	
NS12-V2	12.1-inch TFT	800 × 600 dots	No	Ivory	NS12-TS00-V2	
				Black	NS12-TS00B-V2	
			Yes	Ivory	NS12-TS01-V2	
				Black	NS12-TS01B-V2	
NSH5-V2 Hand-held	5.7-inch STN	320 × 240 dots	No	Black (Emergency stop button: Red)	NSH5-SQR00B-V2	UC, CE
				Black (Stop button: Gray)	NSH5-SQG00B-V2	

NS-Runtime

Product name	Specifications	Media	Model number	Standards	
NS-Runtime	NS-Runtime Installer, PDF manual, hardware key (See note.)	1 license	CD	NS-NSRCL1	-
		3 licenses		NS-NSRCL3	
		10 licenses		NS-NSRCL10	

Note: A hardware key (USB dongle) is required for NS-Runtime operation.

System Requirements

Item	Specifications
OS	Windows XP (Professional or Home Edition)
CPU	Celeron, 1 GHz
Memory size	HDD: 50 MB min., RAM: 256 MB min., 512 MB recommended. 50 MB is required for the Runtime alone. (An additional 280 MB is required if CX-Server is not already installed.)





Programming Devices

Model name	Specifications		Model number	Standards	
	Number of licenses	Media			
CX-One FA Integrated Tool Package Ver. 2.□	The CX-One is an integrated tool package that provides programming and monitoring software for OMRON PLCs and components. The CX-One runs on any of the following operating systems: OS: Windows 98 SE, Me, NT 4.0 (Service Pack 6a), 2000 (Service Pack 3 or higher), XP, or Vista. Note: Windows 95 is not supported.	1 license	CD	CXONE-AL01C-EV2	-
			DVD	CXONE-AL01D-EV2	
		3 licenses	CD	CXONE-AL03C-EV2	
			DVD	CXONE-AL03D-EV2	
		10 licenses	CD	CXONE-AL10C-EV2	
			DVD	CXONE-AL10D-EV2	
		30 licenses	CD	CXONE-AL30C-EV2	
			DVD	CXONE-AL30D-EV2	
		50 licenses	CD	CXONE-AL50C-EV2	
			DVD	CXONE-AL50D-EV2	
The CX-Designer can also be ordered individually using the following model number.					
CX-Designer Ver.2.□	Screen Designer for NS Series OS: Window 98 SE, Me, NT 4.0 (Service Pack 6a), 2000 (Service Pack 3 or higher), XP or Vista. The Ladder Monitor Software is included with CX-Designer version 2.□. Note: The Ladder Monitor Software is used to monitor CS/CJ-series PLC ladder programs from an NS-series PT. A Memory Card and Memory Card Adapter (both sold separately) are required to use the Ladder Monitor Software with the NS8-V1, NS10-V1, or NS12-V1, or with the NS8-V2, NS10-V2, or NS12-V2 with system program version 6.6 or lower.	1 license	CD	NS-CXDC1-V2	-
Cable (See note.) 	Screen transfer cable for DOS/V (CX-Designer ↔ PT)	Length: 2 m		XW2Z-S002	-
	USB Host Cable (For a printer)	Length: 5 m		NS-US52	
	USB Host Cable (For a printer)	Length: 2 m		NS-US22	
	USB-Serial Conversion Cable	Length: 0.5 m		CS1W-CIF31	N
NSH5 Cables	RS-422A cable (loose wires + D-Sub 9-pin)	Length: 10 m		NSH5-422CW-10M	-
	RS-232C cable (loose wires + D-Sub 9-pin)	Length: 3 m		NSH5-232CW-3M	
	RS-232C cable (loose wires + D-Sub 9-pin)	Length: 10 m		NSH5-232CW-10M	
UL-compliant NSH5 Cable	RS-422A cable (loose wires)	Length: 10 m		NSH5-422UL-10M	CU
	RS-232C cable (loose wires + relay cable)	Length: 3 m		NSH5-232UL-3M	
	RS-232C cable (loose wires + relay cable)	Length: 10 m		NSH5-232UL-10M	
PT-to-PLC Connecting Cable	PT connection: 9 pins PLC connection: 9 pins	Length: 2 m		XW2Z-200T	-
		Length: 5 m		XW2Z-500T	
	PT connection: 9 pins PLC peripheral port	Length: 2 m		XW2Z-200T-2	
		Length: 5 m		XW2Z-500T-2	
NSH5 Removable Box Cable	RS-232C Cable (connectors)	Length: 3 m		NSH5-232CN-3M	
		Length: 10 m		NSH5-232CN-10M	
NSH5 Removable Box	-			NSH5-AL001	
NSH5 Wall-mounting Bracket	-			NSH5-ATT02	
NSH5 Visor	-			NSH5-ATT01	

* Use an OMRON USB Host Cable to connect an NS-series PT to a printer.

Use a commercially available USB cable to connect the NS Series main unit with a PictBridge compliant printer.

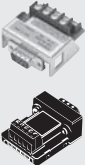
Options

Model name	Specifications	Model number	Standards	
Video Input Unit 	Inputs: 4 channels Signal type: NTSC/PAL	NS-CA001	UC1, CE	
	Input channels: 2 video channels and 1 RGB channel *1 Signal type: NTSC/PAL	NS-CA002		
Special Cable for the Console	Cable length: 2 m	F150-VKP (2 m)	-	
	Cable length: 5 m	F150-VKP (5 m)		
Controller Link Interface Unit 	For Controller Link Communications	NS-CLK21	UC1, CE	
RS-422A Adapter 	Transmission distance: 500 m total length Note: Use this model when connecting PT models without a V□ suffix. Note: PT models with the V□ suffix can also be connected.	NS-AL002	-	
	Transmission distance: 50 m total length Note: Only PT models with a suffix of V□ are connectable. Use the NS-AL002 to connect models without a V□ suffix.	CJ1W-CIF11	UC1, N, L, CE	
Sheet/Cover *2 	Anti-reflection Sheets (5 surface sheets)	NS12/10	NS12-KBA04	-
		NS8	NS7-KBA04	
		NS5	NT30-KBA04	
	Protective Covers (5 pack) (anti-reflection coating)	NS12/10	NS12-KBA05	
		NS8	NS7-KBA05	
		NS5	NT31C-KBA05	
	Protective Covers (5 covers included) (Transparent)	NS12/10	NS12-KBA05N	
		NS8	NS7-KBA05N	
		NS5	NT31C-KBA05N	
Attachment	NT625C/631/631C Series to NS12/10 Series	NS12-ATT01	-	
	NT625C/631/631C Series to NS12/NS10 Series (Black)	NS12-ATT01B		
	NT610C Series to NS12/10 Series	NS12-ATT02		
	NT620S/620C/600S Series to NS8 Series	NS8-ATT01		
	NT600M/600G/610G/612G Series to NS8 Series	NS8-ATT02		
Memory Card 	128MB	HMC-EF183	L, N, CE	
	256 MB	HMC-EF283	CE	
	512 MB	HMC-EF583		
Memory Card Adapter	-	HMC-AP001		
Replacement battery	Battery life: 5 years (at 25°C)	CJ1W-BAT01		
Bar Code Reader	CCD/Handy type barcode reader (RS-232C I/F)	V520-RH21-6	-	

*1. One screen cannot display two video inputs simultaneously.

*2. A Chemical-resistant Cover (NT30-KBA01) is available only for the NS5.

International Standards

- The standards indicated in the "Standards" column are those current for UL, CSA, cULus, cUL, NK, and Lloyd standards and EC Directives as of the end of January 2008. The standards are abbreviated as follows: U: UL: U1: UL (Class I Division 2 Product for Hazardous Locations), C: CSA, UC: cULus, UC1: cULus (Class I Division 2 Product for Hazardous Locations), CU: cUL, N: NK, L: Lloyd, CE: EC Directives.
- Ask your OMRON representatives for the conditions under which the standards were met.

EC Directives

The EC Directives applicable to PLCs include the EMC Directives. OMRON complies with these directives as described below.

EMC Directives

Applicable Standards EMI: EN61131-2
EN61000-6-4
EMS: EN61131-2
EN61000-6-2



PLCs are electrical devices that are incorporated in machines and manufacturing installations. OMRON PLCs conform to the related EMC standards so that the devices and machines into which they are built can more easily conform to EMC standards. The actual PLCs have been checked to ensure conformity to EMC standards. Whether these standards are satisfied for the actual system, however, must be checked by the customer.

EMS-related performance will vary depending on the configuration, wiring, and other conditions of the equipment or control panel in which the PLC is installed. The customer must, therefore, perform final checks to confirm that the overall machine or device conforms to EMC standards.



Note: The applicable EMS standards depend on the product.

Individual Specifications

NS5/NS8/NS10/NS12

Series		NS5-V2																							
Type		5.7-inch Monochrome STN				5.7-inch Color STN				5.7-inch Color TFT															
Appearance																									
Display device		Monochrome LCD				STN color LCD				Color TFT															
Effective display area		Width 117.2 × height 88.4 mm (5.7 inches)																							
Case color		Ivory		Black		Ivory		Black		Ivory		Black													
Built-in Ethernet port		No	Yes	No	Yes	No	Yes	No	Yes	No	Yes	No	Yes												
Model number		NS5-MQ00-V2	NS5-MQ01-V2	NS5-MQ00B-V2	NS5-MQ01B-V2	NS5-SQ00-V2	NS5-SQ01-V2	NS5-SQ00B-V2	NS5-SQ01B-V2	NS5-TQ00-V2	NS5-TQ01-V2	NS5-TQ00B-V2	NS5-TQ01B-V2												
Display colors		16 gradations				256 colors																			
Number of dots		320 dot horizontal × 240 dot vertical																							
View angle		Left/right: 45°, Top: 20°, Bottom: 40°				Left/right: 50°, Top: 45°, Bottom: 50°				Left/right: 70°, Top: 70°, Bottom: 50°															
Screen data capacity		20 Mbytes																							
Image data (BMP or JPG images)		16 gradations				4,096 colors				32,768 colors															
Memory Card		Supported																							
Ladder Monitor function		Not supported																							
Video Input Unit support		Not supported																							
Image displayed via video input		-																							
Controller Link Interface Unit (Wired) support		Not supported																							
Backlight Note: Contact your nearest OMRON representative to replace the backlight.		Service life				50,000 hours min.								75,000 hours min.											
		Brightness adjustment				There are 3 levels that can be set with the touch panel.								Note: The brightness cannot be adjusted much.											
		Backlight error detection				Error is detected automatically, and the RUN indicator flashes green as notification.								Note: This function does not indicate that the service life has been reached. It detects when the backlight is not lit due to a disconnection or other errors. Backlight error detection indicates that all backlights (2) are OFF.											
Touch panel (matrix type)		Method												Resistive membrane											
		Number of switches												300 (20 horizontal × 15 vertical) 16 × 16 dots for each switch											
		Input												Pressure-sensitive											
		Service life												1,000,000 touch operations.											
Display text		Labels												Can be specified in CX-Designer. Font, style, and size can be specified.											
		Numerals, alarms, and character strings												Scalable Gothic: Magnification: 6 to 255 points											
														Rough: Magnification: 1 × 1, 1 × 2, 2 × 1, 2 × 2, 3 × 3, 4 × 4, 8 × 8											
														Standard: Magnification: 1 × 1, 1 × 2, 2 × 1, 2 × 2, 3 × 3, 4 × 4, 8 × 8											
														Fine: Magnification: 1 × 1, 1 × 2, 2 × 1, 2 × 2, 3 × 3, 4 × 4, 8 × 8											
7-segment display: Can display only numerals, dates, and times.																									
Supported languages (42 languages)												Scalable Gothic, rough, standard, and fine can be used for 42 languages. Japanese, simplified Chinese, traditional Chinese, Korean, English, French, German, Italian, Portuguese, Spain, Swedish, Dutch, Finnish, Norwegian, Basque, Catalan, Danish, Albanian, Croatian, Czech, Hungarian, Polish, Romanian, Slovak, Slovenian, Bulgarian, Belarusian, Russian, Serbian, Macedonian, Ukrainian, Georgian, Icelandic, Afrikaans, Faroese, Indonesian, Greek, Turkish, Estonian, Latvian, Lithuanian, Thai (supported only with scalable Gothic font)													

Series		NS5-V2		
Type		5.7-inch Monochrome STN	5.7-inch Color STN	5.7-inch Color TFT
Text attributes	Color	Monochrome, 16 gradations	256 colors	
	Font style (only when vector font is specified)	Bold or italic		
	Vertical alignment	Top, center, or bottom		
	Horizontal alignment	Left-justified, centered, or right-justified		
Flicker	Objects supporting flicker	Functional objects: Select from up to 10 types of registered flicker settings. The flicker speed and flicker range can be set. Fixed objects: Select from three flicker types.		
Numeral units and scale settings		1,000 max.		
Alarm/event settings		5,000 max.		
Memory Card	Interface	One ATA-Compact Flash interface slot		
	Functions	Used to transfer and store screen data, store logging data, and store history data. (Alarm/Event History, Operation Log, and Error Log generated during Macro execution).		
Expansion interface		For Expansion Interface Units		
Serial Communications	Port A	Connector	Conforms to EIA RS-232C. D-Sub female 9-pin connector 5-V output (250 mA max.) through pin 6 (See note.) Note: The 5-V outputs of serial ports A and B cannot be used at the same time.	
		Functions	Host (PLC) access: 1:N NT Links (connections with CS/CJ/CP-series PLCs and C200HX/HG/HE(-Z) PLCs), 1:1 NT Links, or Host Link (connections with C Series or CVM1/CV-series PLCs) Direct access to Temperature Controllers using Smart Active Parts: CompoWay/F and bar code reader connections (Read directly from display.)	
	Port B	Connector	Conforms to EIA RS-232C. D-Sub female 9-pin connector 5-V output (250 mA max.) through pin 6 (See note.) The 5-V outputs of serial ports A and B cannot be used at the same time. Note: The 5-V outputs of serial ports A and B cannot be used at the same time.	
		Functions	Host (PLC) access: 1:N NT Links (connections with CS/CJ/CP-series PLCs and C200HX/HG/HE(-Z) PLCs) or 1:1 NT Links (connections with C Series or CVM1/CV-series PLCs) Direct access to Temperature Controllers using Smart Active Parts: CompoWay/F and bar code reader connections (Read directly from display.)	
USB SLAVE Specifications	USB rating	USB1.1		
	Connector	TYPE-B (Slave)		
	Functions	Connection with the CX-Designer (for screen data transfers)		
USB HOST Specifications	USB rating	None		
	Connector			
	Functions			
Built-in Ethernet Specifications (NS□-□□01-V2 only)	Conformance standards	Conforms to IEEE 802.3/Ethernet (10Base-T/100Base-TX).		
	Function	Host (PLC) access and connection with the CX-Designer (for screen data transfers)		
Controller Link (Wired-type) Specifications	Baud rate	-		
	Transmission path	-		
	Functions	-		
Video Input Specifications	Resolution	-		
	Input signal	-		
	Number of video inputs	-		

Series	NS8-V2				NS10-V2				NS12-V2			
Type	8.4-inch Color TFT				10.4-inch Color TFT				12.1-inch Color TFT			
Appearance												
Display device	High-definition TFT color LCD				High-definition TFT color LCD				High-definition TFT color LCD			
Effective display area	Width 170.9 × height 128.2 mm (8.4 inches)				Width 215.2 × height 162.4 mm (10.4 inches)				Width 246.0 × height 184.5 mm (12.1 inches)			
Case color	Ivory		Black		Ivory		Black		Ivory		Black	
Built-in Ethernet port	No	Yes	No	Yes	No	Yes	No	Yes	No	Yes	No	Yes
Model number	NS8-TV00-V2	NS8-TV01-V2	NS8-TV00B-V2	NS8-TV01B-V2	NS10-TV00-V2	NS10-TV01-V2	NS10-TV00B-V2	NS10-TV01B-V2	NS12-TS00-V2	NS12-TS01-V2	NS12-TS00B-V2	NS12-TS01B-V2
Display colors	256 colors				256 colors				256 colors			
Number of dots	640 dot horizontal × 480 dot vertical				640 dot horizontal × 480 dot vertical				800 dot horizontal × 600 dot vertical			
View angle	Right/left: ±65°, Top: 50°, Bottom: 60°				Right/left: ±60°, Top: 35°, Bottom: 65°				Right/left: ±60°, Top: 45°, Bottom: 75°			
Screen data capacity	60 Mbytes				60 Mbytes				60 Mbytes			
Image data (BMP or JPG images)	32,768 colors				32,768 colors				32,768 colors			
Memory Card	Supported				Supported				Supported			
Ladder Monitor function	Supported				Supported				Supported			
Video Input Unit support	Supported				Supported				Supported			
Image displayed via video input	260,000 colors				260,000 colors				260,000 colors			
Controller Link Interface Unit (Wired) support	Not supported				Supported				Supported			
Backlight	50,000 hours min.				50,000 hours min.				50,000 hours min.			
Note: Contact your nearest OMRON representative to replace the backlight.	Service life	Note: This is the estimated time before brightness is reduced by half at room temperature and humidity. It is not a guaranteed value. The service life will be dramatically shortened if PT is used at low temperatures. For example, using the PT at temperatures of 0°C will reduce the service life to approximately 10,000 hours (reference value).										
	Brightness adjustment	There are 3 levels that can be set with the touch panel. Note: The brightness cannot be adjusted much.										
	Backlight error detection	Error is detected automatically, and the RUN indicator flashes green as notification. Note: This function does not indicate that the service life has been reached. It detects when the backlight is not lit due to a disconnection or other errors. Backlight error detection indicates that all backlights (2) are OFF.										
Touch panel (matrix type)	Method	Resistive membrane										
	Number of switches	768 (32 horizontal × 24 vertical) 20 × 20 dots for each switch			1,200 (40 horizontal × 30 vertical) 16 × 16 dots for each switch			1,900 (50 horizontal × 38 vertical) 16 × 16 dots for each switch				
	Input	Pressure-sensitive										
	Service life	1,000,000 touch operations.										
Display text	Labels	Can be specified in CX-Designer. Font, style, and size can be specified.										
	Numerals, alarms, and character strings	Scalable Gothic: Magnification: 6 to 255 points										
		Rough: Magnification: 1 × 1, 1 × 2, 2 × 1, 2 × 2, 3 × 3, 4 × 4, 8 × 8										
		Standard: Magnification: 1 × 1, 1 × 2, 2 × 1, 2 × 2, 3 × 3, 4 × 4, 8 × 8										
Supported languages (42 languages)	Fine: Magnification: 1 × 1, 1 × 2, 2 × 1, 2 × 2, 3 × 3, 4 × 4, 8 × 8											
	7-segment display: Can display only numerals, dates, and times.											
Supported languages (42 languages)	Scalable Gothic, rough, standard, and fine can be used for 42 languages. Japanese, simplified Chinese, traditional Chinese, Korean, English, French, German, Italian, Portuguese, Spain, Swedish, Dutch, Finnish, Norwegian, Basque, Catalan, Danish, Albanian, Croatian, Czech, Hungarian, Polish, Romanian, Slovak, Slovenian, Bulgarian, Belarusian, Russian, Serbian, Macedonian, Ukrainian, Georgian, Icelandic, Afrikaans, Faroese, Indonesian, Greek, Turkish, Estonian, Latvian, Lithuanian, Thai (supported only with scalable Gothic font)											

Series		NS8-V2	NS10-V2	NS12-V2
Type		8.4-inch Color TFT	10.4-inch Color TFT	12.1-inch Color TFT
Text attributes	Color	Monochrome, 16 gradations	256 colors	
	Font style (only when vector font is specified)	Bold or italic		
	Vertical alignment	Top, center, or bottom		
	Horizontal alignment	Left-justified, centered, or right-justified		
Flicker	Objects supporting flicker	Functional objects: Select from up to 10 types of registered flicker settings. The flicker speed and flicker range can be set. Fixed objects: Select from three flicker types.		
Numeral units and scale settings		1,000 max.		
Alarm/event settings		5,000 max.		
Memory Card	Interface	One ATA-Compact Flash interface slot		
	Functions	Used to transfer and store screen data, store logging data, and store history data. (Alarm/Event History, Operation Log, and Error Log generated during Macro execution).		
Expansion interface		For Expansion Interface Units		
Serial Communications	Port A	Connector	Conforms to EIA RS-232C. D-Sub female 9-pin connector 5-V output (250 mA max.) through pin 6 (See note.) Note: The 5-V outputs of serial ports A and B cannot be used at the same time.	
		Functions	Host (PLC) access: 1:N NT Links (connections with CS/CJ/CP-series PLCs and C200HX/HG/HE(-Z) PLCs), 1:1 NT Links, or Host Link (connections with C Series or CVM1/CV-series PLCs) Direct access to Temperature Controllers using Smart Active Parts: CompoWay/F and bar code reader connections (Read directly from display.)	
	Port B	Connector	Conforms to EIA RS-232C. D-Sub female 9-pin connector 5-V output (250 mA max.) through pin 6 (See note.) The 5-V outputs of serial ports A and B cannot be used at the same time. Note: The 5-V outputs of serial ports A and B cannot be used at the same time.	
		Functions	Host (PLC) access: 1:N NT Links (connections with CS/CJ/CP-series PLCs and C200HX/HG/HE(-Z) PLCs) or 1:1 NT Links (connections with C Series or CVM1/CV-series PLCs) Direct access to Temperature Controllers using Smart Active Parts: CompoWay/F and bar code reader connections (Read directly from display.)	
USB SLAVE Specifications	USB rating	USB1.1		
	Connector	TYPE-B (Slave)		
	Functions	Connection with the CX-Designer (for screen data transfers)		
USB HOST Specifications	USB rating	USB1.1		
	Connector	TYPE-A (Host)		
	Functions	Connection with a printer (for hard copies) • Manufacturer: EPSON or Canon • Recommended models: EPSON: PM-2200C, PM-930C, PM-870C, PM-740C, PM-900C, PM-D600, PM-G720, PM-G730, and PX-A650 Canon: BJ M70, BJ M40, PIXUS 550i, PIXUS 50i, PIXUS 80i, PIXUS iP2000, PIXUS iP3100, PIXUS iP4100, and PIXUS iP4100R		
Built-in Ethernet Specifications (NS□□□01-V2 only)	Conformance standards	Conforms to IEEE 802.3/Ethernet (10Base-T/100Base-TX).		
	Function	Host (PLC) access and connection with the CX-Designer (for screen data transfers)		
Controller Link (Wired-type) Specifications	Baud rate	–	2 M/1 M/500 K	
	Transmission path	–	Shielded twisted-pair cable (special cable)	
	Functions	–	Host (PLC) access and data links	
Video Input Specifications	Resolution	NS-CA001: 320 × 240, 640 × 480, 800 × 600 dots	NS-CA002: User-defined size	
	Input signal	NS-CA001: NTSC composite video or PAL	NS-CA002: NTSC composite video or PAL	
	Number of video inputs	NS-CA001: Number of cameras: 4 max.	NS-CA002: 2 cameras + RGB	

General Specifications

Rated power supply voltage	24 VDC
Allowable voltage range	20.4 to 27.6 VDC (24 VDC \pm 15%)
Power consumption	25 W max. (15 W max. for the NS5)
Ambient operating temperature	0 to 50°C *1 Note: The ambient operating temperature is subject to the following restrictions according to the mounting angle. Mounting angle of 0 to 30° to the horizontal: • When no Expansion Units are mounted, the operating temperature range is 0 to 45°C. • When a Video Input Unit or a Controller Link Interface Unit is mounted, the ambient operating temperature is 0 to 40°C. Mounting angle of 30 to 90° to the horizontal: Operating temperature range of 0 to 50°C
Storage temperature	-20 to 60°C *1
Ambient operating humidity	35 to 85% (0 to 40°C) 35 to 60% (40 to 50°C) (with no condensation)
Operating environment	No corrosive gases.
Noise immunity	Conforms to IEC61000-4-4, 2 kV (power lines).
Vibration resistance (during operation)	10 to 57 Hz, 0.075 mm amplitude, 57 to 150 Hz, 9.8 m/s ² 30 min each in X, Y, and Z directions
Shock resistance (during operation)	147 m/s ² 3 times each in direction of X, Y, and Z
Weight	NS5: 1.0 kg max.; NS8: 2.0 kg max.; NS10: 2.3 kg max.; NS12: 2.5 kg max.
Degree of protection	Front operating panel: Equivalent to IP65 Oil-proof type and NEMA4. *2 Note: May not be applicable in locations with long-term exposure to oil.
Ground	Ground to 100 Ω or less.
Battery life	5 years (at 25°C): Replace battery within 5 days after the battery runs low (indicator lights orange).
Applicable standards	Certified for conformance to UL 508, UL 1604, EMC Directive, NK, and LR Standards.

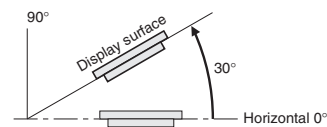

*1. Operate the PT within the temperature and humidity ranges shown in the following diagram.

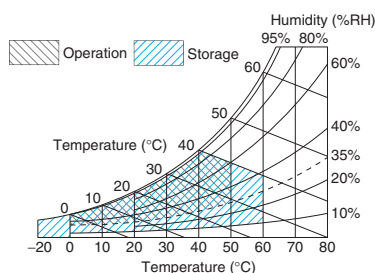

*2. NS5 only.

NSH5 Hand-held PT

Series	NSH5-V2	
Type	5.7-inch Color STN (Hand-held Version)	
Appearance	 Emergency stop button (Red)	 Stop button (Gray)
Case color	Black	
Built-in Ethernet port	No	
Model number	NSH5-SQROOB-V2 (Emergency stop button: Red)	NSH5-SQGOOB-V2 (Stop button: Gray)
Rated power supply voltage	24 VDC	
Allowable voltage range	20.4 to 27.6VDC (24 VDC \pm 15%)	
Power consumption	10 W max.	
Ambient operating temperature	0 to 40°C	
Storage temperature	-20 to 60°C	
Ambient operating humidity	35% to 85% (0 to 40°C) with no condensation	
Operating environment	No corrosive gases.	
Noise immunity	Common mode: 1,000 Vp-p (between power supply terminals and panel) Normal mode: 300 Vp-p Pulse width: 100 ns to 1 ms, Rise time: 1-ns pulse	
Vibration resistance (during operation)	10 to 57 Hz, 0.075 mm amplitude, 57 to 150 Hz, 9.8 m/s ² 30 min each in X, Y, and Z directions	
Shock resistance (during operation)	147 m/s ² 3 times each in direction of X, Y, and Z	
Weight	1 kg max.	
Degree of protection	Equivalent to IP65.	
Ground	Ground to 100 Ω or less.	
Battery life	5 years (at 25°C): Replace battery within 5 days after the battery runs low (indicator lights orange).	
Applicable standards	Certified for conformance to UL 508, EMC Directive, and EN 60204-1.	

Connectable PLCs

Link Connection

PLC series	PLC model name	Model number	Specifications
C Series	CQM1	CQM1-CPU□□-V1	With RS-232C connector (9-pin type)
	CQM1H	CQM1H-CPU□□	
	CPM1	CPM1-□□CDR-□+CPM1-CIF01	Connect to peripheral port.
	CPM1A	CPM1A-□□CD□-□+CPM1-CIF01	
	CPM2A	CPM2A-□□CD□□-□+CPM1-CIF01	Connect to RS-232C or peripheral port.
	CPM2C	CPM2C-10/20□□□□□□□□ *1	
	C200HS	C200HS-CPU□	With RS-232C connector (9-pin type)
	C200HE(-Z)	C200HE-CPU□(-Z) *2	
	C200HG(-Z)	C200HG-CPU□(-Z) *2	
	C200HX(-Z)	C200HX-CPU□(-Z) *2	
CVM1/CV Series	CV500/1000/2000	CV500/1000/2000-CPU□-V1	With RS-232C connector (switching/9-pin type)
	CVM1	CVM1-CPU□-V2	

*1. Use an Adapter Cable (CPM2C-CN111 or CS1W-CN114/118), CPM1-CIF01 RS-232C Adapter, or CPM1-CIF11 RS-422A Adapter to connect.

*2. A C200HW-COM02(-V1), C200HW-COM04(-V1), C200HW-COM05(-V1), or C200HW-COM06(-V1) Communications Board is required.

Note: The NS-Runtime can be connected only to CS/CJ/CP/CV-series PLCs. Use a peripheral bus (toolbus), Host Link, or Ethernet connection.

1:N NT Link Connection

PLC series	PLC model name	Model number	Specifications
CS series	CS1G	CS1G-CPU□□(-V1) *1	With RS-232C connector (9-pin type)
		CS1G-CPU□□H *1	
	CS1H	CS1H-CPU□□(-V1) *1	
		CS1H-CPU63H/CPU64H/CPU65H/ CPU66H/CPU67H *1	
CS1D	CS1D-CPU□□H *1		
CJ series	CJ1G	CJ1G-CPU□□H *2	
	Loop-control CPU Unit	CJ1G-CPU□□P	
	CJ1H	CJ1H-CPU□□H *2	
	CJ1M	CJ1M-CPU□□ *2	
CP series	CP1H	CP1H-□□ *3	Connect to the RS-232C connector of a CP1W-CIF01 RS-232C Option Board.
	CP1L	CP1L-M□□/L□□ *3	
C series	CQM1H	CQM1H-CPU61/51 with a CQM1H-SCB41 Serial Communications Board	With RS-232C connector (9-pin type)
	C200HE(-Z)	C200HE-CPU32(-Z) *4/CPU42(-Z)	
	C200HG(-Z)	C200HG-CPU33(-Z) *4/CPU43(-Z)/ CPU53(-Z) *4/CPU63(-Z)	
	C200HX(-Z)	C200HX-CPU34(-Z) *4/CPU44(-Z)/ CPU54(-Z) *4/CPU64(-Z)/CPU65-Z/ CPU85-Z	

*1. Connection is also possible to a CS1W-SCB□□-V1 Serial Communications Board or CS1W-SCU□□-V1 Serial Communications Unit.

*2. Connection is also possible to the CJ1W-BCU□□-V1 Serial Communications Unit.

*3. The SPMA, machine monitor function, and switch box function are not supported when a CP-series PLC is connected.

*4. A C200HW-COM02/COM04/COM05/COM06(-V1) Communications Board is required.

Note: The NS-Runtime can be connected only to CS/CJ/CP/CV-series PLCs. Use a peripheral bus (toolbus), Host Link, or Ethernet connection.

Connecting by Host Link

PLC series	PLC model name	Model number	Specifications
C series	CPM1	CPM1-□□CDR-□/CPM1A-□□CD□-□	RS-232C or RS-422A adapter connected to peripheral port
	CPM2A	CPM2A-□□CD□□-□	With RS-232C connector (9-pin type)
	CPM2C	CPM2C-10/20□□□□□□-□	Communications connectors include both a peripheral port and RS-232C port (branching possible through CPM2C-CN111 Conversion Cable). Used as separate peripheral and RS-232C ports through CS1WCN114/118 Conversion Cable.
	CQM1	CQM1-CPU□□-V1	With RS-232C connector (9-pin type)
	CQM1H	CQM1H-CPU□□	With RS-232C connector (9-pin type) (CQM1H-CPU11: peripheral port only)
	C200HS	C200HS-CPU□□	With RS-232C connector (switching/9-pin type)
	C200HE(-Z)	C200HE-CPU□□(-Z) *1	
	C200HG(-Z)	C200HG-CPU□□(-Z) *1	
	C200HX(-Z)	C200HX-CPU34 (-Z) *1/CPU44 (-Z)/CPU54 (-Z) *1/CPU64 (-Z)/CPU65-Z/CPU85-Z	
CS series	CS1G	CS1G-CPU□□(-V1) *2	With RS-232C connector (9-pin type)
		CS1G-CPU□□H *2	
	CS1H	CS1H-CPU□□(-V1) *2	
		CS1H-CPU□□H *2	
CJ series	CJ1G	CJ1G-CPU□□H *3	With RS-232C connector (9-pin type)
	Loop-control CPU Unit	CJ1G-CPU□□P	
	CJ1H	CJ1H-CPU□□H *3	
	CJ1M	CJ1M-CPU□□ *3	
CP series	CP1H	CP1H-□□ *4	Connect to the RS-232C connector of a CP1W-CIF01 RS-232C Option Board.
	CP1L	CP1L-M□□/L□□ *4	
CVM1/CV series	CV500/1000/2000	CV500-CPU01-V1/CV1000-CPU01-V1/ CV2000-CPU01-V1	With RS-232C connector (switching/9-pin type)
	CVM1	CVM1-CPU□□-V2	

*1. A C200HW-COM02/COM04/COM05/COM06(-V1) Communications Board is required.

*2. Connection is also possible to a CS1W-SCB□□-V1 Serial Communications Board or CS1W-SCU□□-V1 Serial Communications Unit.

*3. Connection is also possible to the CJ1W-SCU□□-V1 Serial Communications Unit.

*4. The SPMA, machine monitor function, and switch box function are not supported when a CP-series PLC is connected.

Note: The NS-Runtime can be connected only to CS/CJ/CP/CV-series PLCs. Use a peripheral bus (toolbus), Host Link, or Ethernet connection.

Connecting to Another Company's PLC

Manufacturer	Series	CPU	Communication Unit/Adapter/Board	Connection diagram	
Mitsubishi Electric	A Series	A1SHCPU A2USCPU A2USHCPU-S1	Computer Link Unit A1SJ71UC24-R□ A1SJ71UC24-PRF		1:1
		A2ACPU	Computer Link Unit AJ71UC24		
	FX Series	FX0N FX1S FX1N FX1NC FX2N FX3UC	Communication special adapter FX3U-232-ADP FX2NC-232ADP FX0N-232-ADP Communication expansion board FX□□-232-BD		1:1
	Q/QnA Series	Q00CPU Q01CPU	RS-232C port on the CPU Module		1:1
		Q00CPU Q01CPU Q00JCPU Q02CPU Q02HCPU Q06HCPU Q12HCPU Q25HCPU	Serial Communications Module QJ71C24N-R2 QJ71C24N-R4 QJ71C24N		1:N
		Q2ASCPU Q2ASCPU-S1 Q2ASHCPU Q2ASHCPU-S1	Serial Communications Module A1SJ71QC24N		
Siemens	S7-300 Series	CPU313 CPU315-2DP CPU317-2PN/DP	SIMATIC S7 HMI Adapter 6ES7 972-0CA1□-0XA0		1:1
Rockwell (Allen-Bradley)	SLC500	SLC5/03 SLC5/04 SLC5/05	RS-232C port on the CPU Module	RS-232C	1:1
	MicroLogix	MicroLogix 1500	RS-232C port on the CPU Module	RS-232C	1:1
	ControlLogix	Logix5555	RS-232C port on the CPU Module	RS-232C	1:1
	CompactLogix	1769-L31	RS-232C port on the CPU Module	RS-232C	1:1
	PLC-5	PLC-5/20	RS-232C port or RS-485 port on the CPU Module	RS-232C/RS-485 (4-wire)	1:1

Connectable Motion Controllers

Series	CPU	Communication Unit	Connection
Trajexia	TJ1-MC16 TJ1-MC04	Ethernet port on the Controller	Ethernet

Connecting to Another Company's PLC

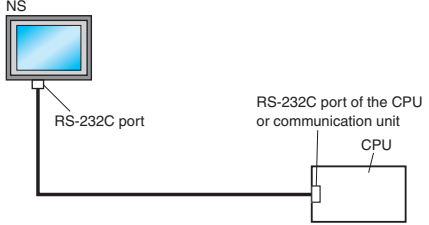
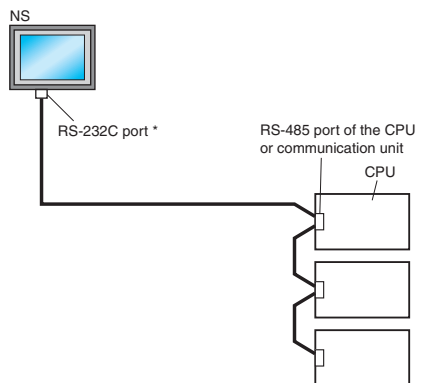
Manufacturer	Series	CPU	Communications Unit/Adapter/Board	Connection
Yaskawa Electric	MP900 Series	MP920	(Use the RS-232C port or RS-485 port on the Machine Controller)	<p>RS-232C</p>  <p>1:1</p>
	MP2000 Series	MP2200	Serial Communication Module 2171F-01	<p>RS-485</p>  <p>1:N</p> <p>* To connect using RS-485, a converter (e.g. NS-AL002) is required. Up to 32 controllers can be connected when using RS-485.</p>

Connectable Inverters

Series	Communication Unit	Connection
3G3MV	(Use the RS-422/485 terminal on the Inverter)	RS-422/RS-485 (4-wire)/RS-485 (2-wire)
3G3JV	3G3JV-PSI485J	

Connectable Temperature Controllers

The following Temperature Controllers can be connected directly to an NS-series PT.

Unit name	Series	Model	Remarks
Modular Temperature Controller	EJ1	EJ1-EDU End Unit	
Modular Temperature Controller	E5ZN	E5ZN-SCT24S Terminal Unit	
Digital Controller	E5AR	E5AR-□□□□□□□□□□-FLK	
	E5ER	E5ER-□□□□□□□□□□-FLK	
Digital Temperature Controller	E5CN	E5CN-□□□□□□T-FLK Multi-input (Thermocouple/Resistance Thermometer) Type	SAP screens are available.
		E5CN-□□□□□□L-FLK Analog Input Type	
	E5AN/E5EN	E5AN-□□□□□□T-FLK Multi-input (Thermocouple/Resistance Thermometer) Type	
		E5AN-□□□□□□L-FLK Analog Input Type	
		E5EN-□□□□□□T-FLK Multi-input (Thermocouple/Resistance Thermometer) Type	
		E5EN-□□□□□□L-FLK Analog Input Type	
	E5GN	E5GN-□□□□TC-FLK Thermocouple Input Type	
		E5GN-□□□□P-FLK Resistance Thermometer Input Type	

Note: The NS-Runtime cannot be connected directly to a Temperature Controller.

Connection Configurations

Transferring Screens (Connecting the CX-Designer and PT)

Connecting to the Computer's RS-232C Port

Use a XW2Z-S002 Cable for screen transfers.

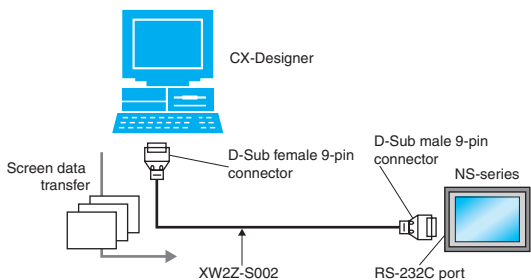

Connecting to the Computer's USB Port

Use a CS1W-CIF31 USB-Serial Conversion Cable and XW2Z-S002 Cable for screen transfers.

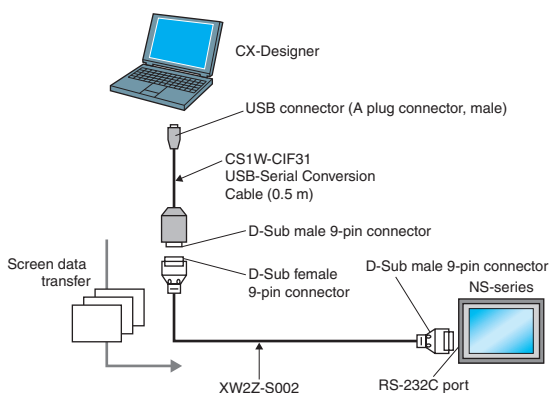

A commercially available USB cable can be used as well. *

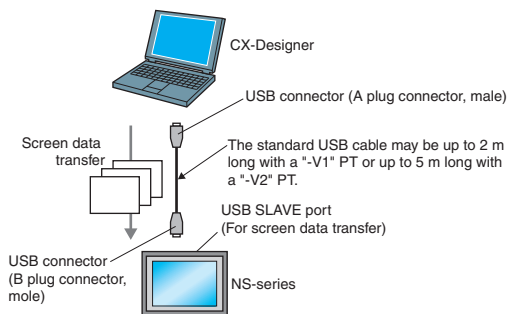

* Commercially available USB cables cannot be used for the NS main units of which the lot. No. is prior to 0325 (made on Feb. 3, 2005).

Connecting to the Computer's LAN (Ethernet) Port

Connecting Directly (1:1) to the Computer

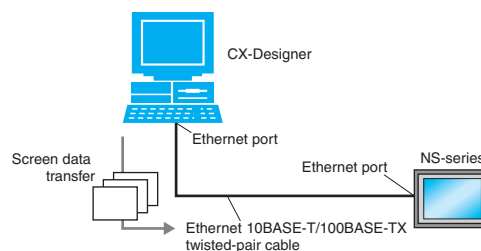

Connecting to the Computer through a Hub

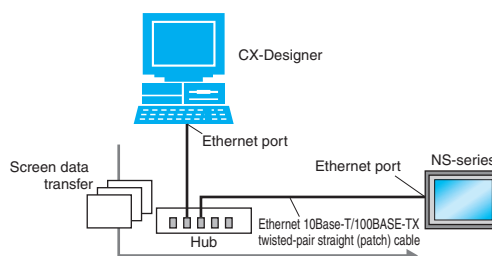

Note: An NS-series PT can also connect to a network configured for 10Base-5 when using a hub and transceiver set for 10Base-5 communications.

Connecting through a PLC

If the PLC is a CS/CJ-series PLC, screen data can be transferred to an NS-series PT through the PLC. *

Using a Serial → Serial Connection

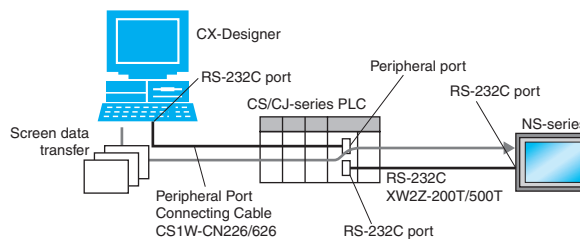

Using an Ethernet → Serial Connection

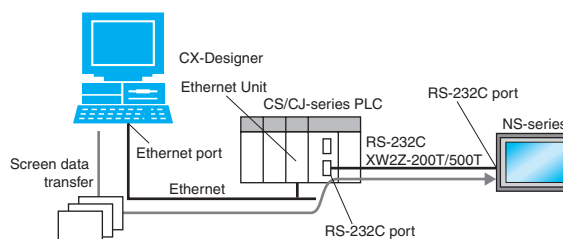

* Not available for the CPU units of which the lot No. is prior to 03020.

Operation (Connection between NS-series PT and PLC)

Using a Serial Connection

When connecting to a CS/CJ-series PLC's RS-232C port, use an XW2Z-200T/500T Cable between the PT and PLC.

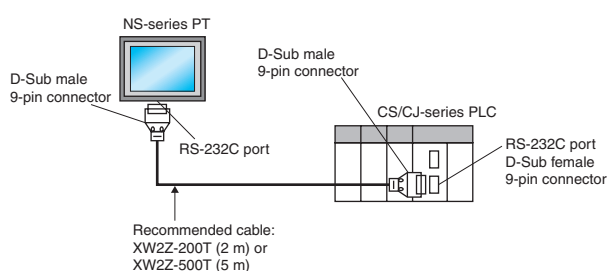

When connecting to a CS/CJ-series PLC's peripheral port, use an XW2Z-200T-2/500T-2 Cable between the PT and PLC.

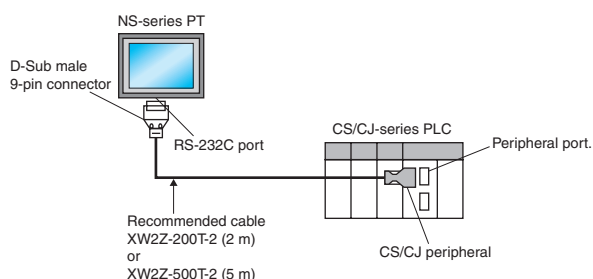

Using an Ethernet Connection

Connecting Directly (1:1) to the Computer

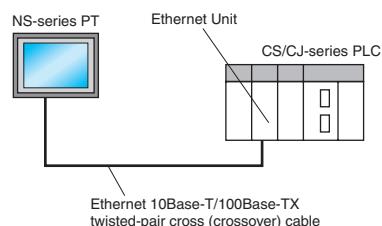

Connecting to the Computer via a Hub

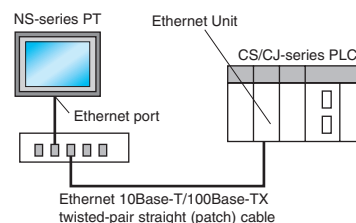

Note: An NS-series PT can also connect to a network configured for 10Base-5 when using a hub and transceiver set for 10Base-5 communications.

In addition, the NS-series PT can be connected through Controller Link by mounting an NS-CLK21 Controller Link Interface Unit to the PT.

Smart Active Parts (SAP) Library Contents

For monitor setting

More than 3,000 Library parts (Smart Active Parts) are available, which can directly access OMRON PLCs and components. The objects can just be pasted from the Smart Active Parts (SAP Library) Library to the screen; it is completely unnecessary to create screens and ladder programming. The following Smart Active Parts are provided on the CX-One/CX-Designer.

For CS/CJ CPU Unit

Error Log Monitor, Online Battery Change Button, etc.

For Serial Communications Boards/Units

Communications Status Displays (Error Monitor), Ports Settings, etc.

For Ethernet Units/CLK Units

Network Status Displays (Error Monitor and Network Node Status), etc.

For MC/MCH Unit

JOG Running, Search Zero Position, Program Running, Error Displays, I/O Status Monitor, PV Monitor, etc.

For NC/NCF Unit

JOG Running, Direct Running, Memory Running (NC Only), Error Displays I/O Status Monitor, PV Monitor, etc.

For Wireless Terminals for WT30

Monitoring Slave Operating Status in a Wireless Environment

For Servo (R88D-WT, R7D-AP) (See note 1.)

PV Monitor, Parameter Settings, Error Displays, Driver Information Displays, I/O Status Monitor, etc.

For Inverters (See note 1.)

Rotation Speed/Monitoring Output Frequency, Other Parameter Settings, etc.

For DeviceNet DRT2

DRT2 Maintenance/Status Information, IN/OUT Information, etc.

For Temperature Controllers (E5□R, E5ZN, E5□N, EJ1 and CJ1W-TC) (See note 2.)

Operation Monitor, PID Settings, SP Settings, Alarm Settings, Input Shift Settings, etc.

For Sensors (E3X-DRT)

Threshold Settings, Monitoring Light Reception Levels, etc.

For the SmartSlice GRT1 Series

Communications Unit Status, Warning/Alarm Flags, Network Joining/Leaving Status

For CompoNet

Master/Save Monitor, Maintenance Information, Analog I/O Monitor, IN/OUT Information Monitor, etc.

For Multi-point Power Controllers (G3ZA)

Process Variable Read, Status Read, Heater Current Read, Manipulated Variable Write, etc.

For NE1A Safety Network Controllers and DST1 Safety I/O Terminals

Maintenance Information, IN/OUT Information Monitor, Error Status Information, etc.

- Note:**
1. Smart Active Parts require a Serial Communications Units/Boards (version 1.2 or later).
 2. The NS-Runtime cannot be connected directly to a Temperature Controller.

For Troubleshooter

A Troubleshooter SAP Library is available to troubleshoot each Unit in the PLC. When an error occurs in a Unit, the Troubleshooter SAP Library provides an easy-to-understand explanation of the cause of the error as well as the countermeasures.

The CX-One/CX-Designer includes the following Troubleshooter SAP library as standard.

DeviceNet unit

NC unit

NCF unit

Standard I/O unit

Analog Input / Output / I/O unit

SCU unit

High speed counter unit

CLK unit

ID sensor unit

Troubleshooter SAP for a Position Control Unit

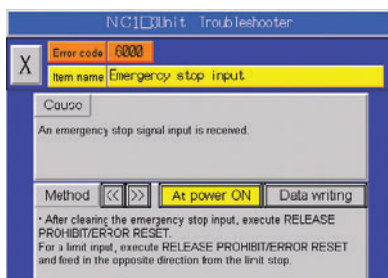

Troubleshooter SAP for Basic I/O Unit

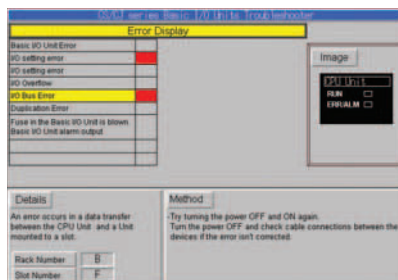

Dimensions

NS12/10

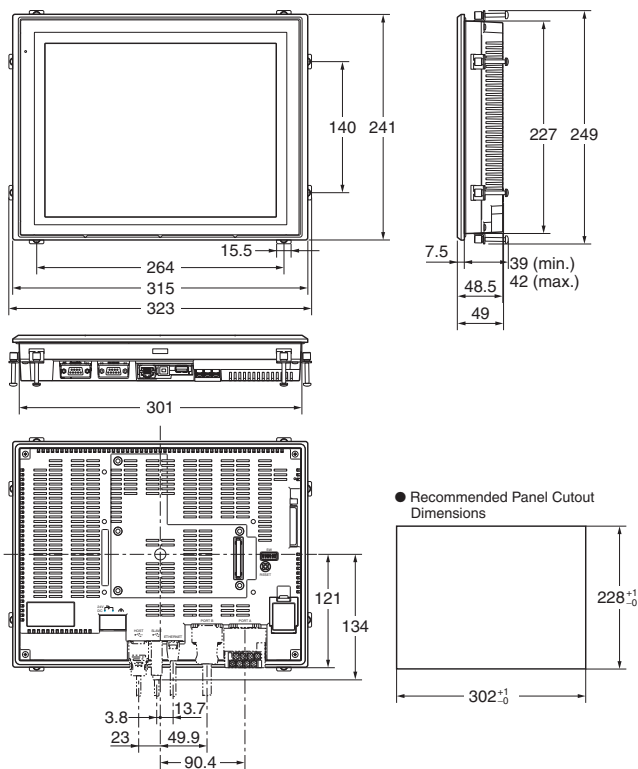

NS8

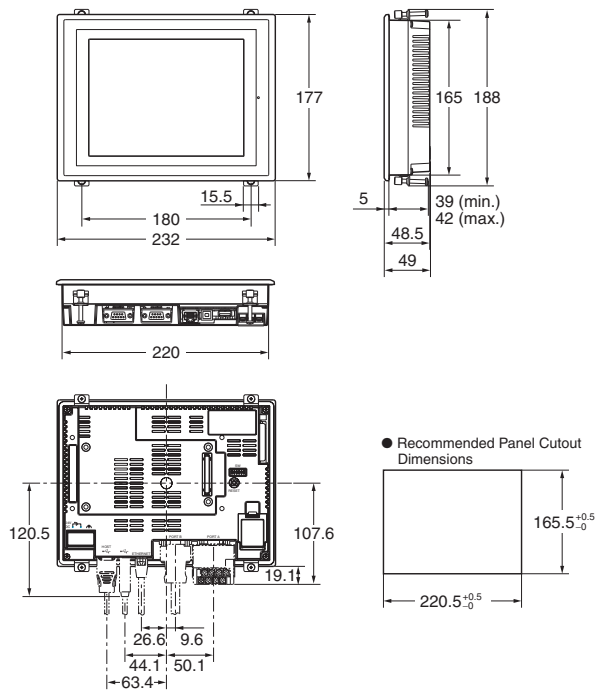

NS5

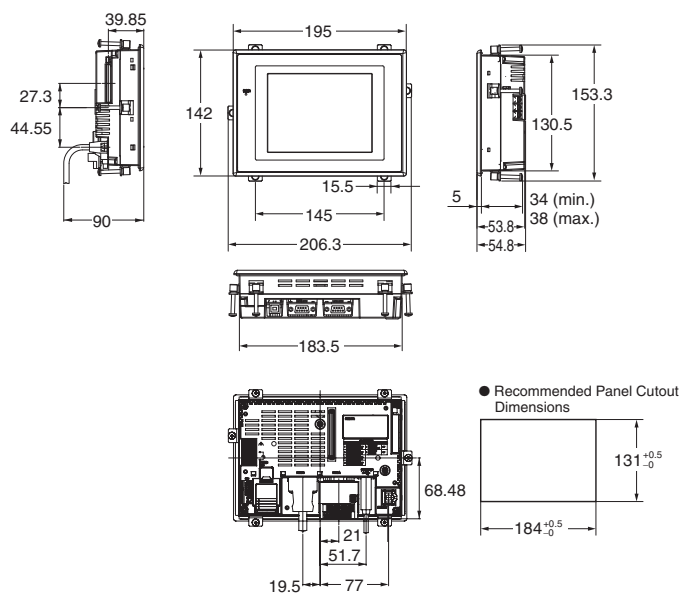

NSH5

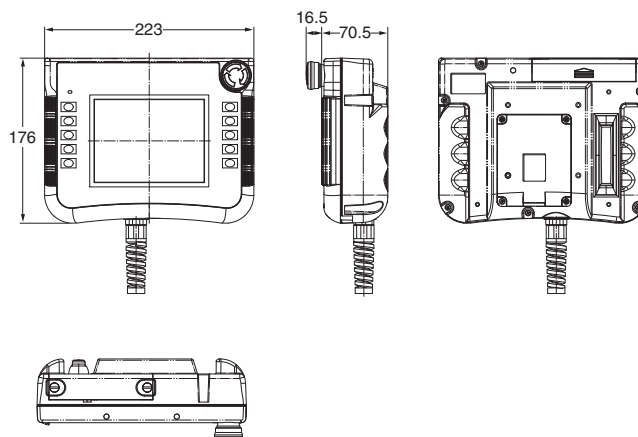

**Video Input Unit
NS-CA001 (with Cover)**

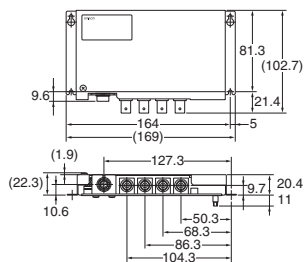

**RGB/Video Input Unit
NS-CA002 (with Cover)**

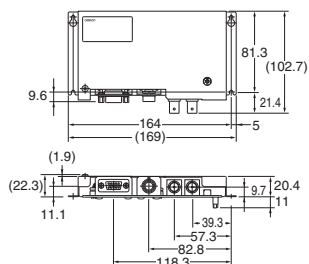

**Controller Link Interface Unit
NS-CLK21 (with Cover)**

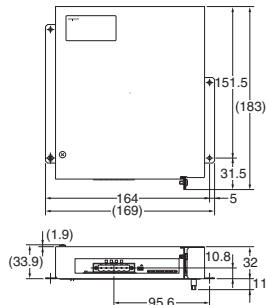

Related Manual

The related manuals are organized as shown in the chart below.

Cat.No.	Model	Name	Applications	Description
V072-E1	NS12-TS00□-V1/-V2 NS12-TS01□-V1/-V2 NS10-TV00□-V1/-V2 NS10-TV01□-V1/-V2 NS8-TV00□-V1/-V2 NS8-TV01□-V1/-V2 NS8-TV10□-V1 NS8-TV11□-V1 NS5-SQ00□-V1/-V2 NS5-SQ01□-V1/-V2 NS5-TQ00□-V2 NS5-TQ01□-V2 NS5-MQ00□-V2 NS5-MQ01□-V2	Programmable Terminals NS-Series SETUP MANUAL	To learn how to use the programmable terminal NS Series	Describes how to connect or use the NS Series.
V073-E1	NS12-TS00□-V1/-V2 NS12-TS01□-V1/-V2 NS10-TV00□-V1/-V2 NS10-TV01□-V1/-V2 NS8-TV00□-V1/-V2 NS8-TV01□-V1/-V2 NS8-TV10□-V1 NS8-TV11□-V1 NS5-SQ00□-V1/-V2 NS5-SQ01□-V1/-V2 NS5-TQ00□-V2 NS5-TQ01□-V2 NS5-MQ00□-V2 NS5-MQ01□-V2	Programmable Terminals NS-Series PROGRAMMING MANUAL	To learn how to program using the programmable terminal NS Series	Describes the NS Series screen configurations, specifications of functional parts, and other functions.
V088-E1	NS-CXDC1-V2	CX-Designer USER'S MANUAL	To learn how to use the screen data creation software CX-Designer	Describes how to install and use the CX-Designer.

Read and Understand This Catalog

Please read and understand this catalog before purchasing the products. Please consult your OMRON representative if you have any questions or comments.

Warranty and Limitations of Liability

WARRANTY

OMRON's exclusive warranty is that the products are free from defects in materials and workmanship for a period of one year (or other period if specified) from date of sale by OMRON.

OMRON MAKES NO WARRANTY OR REPRESENTATION, EXPRESS OR IMPLIED, REGARDING NON-INFRINGEMENT, MERCHANTABILITY, OR FITNESS FOR PARTICULAR PURPOSE OF THE PRODUCTS. ANY BUYER OR USER ACKNOWLEDGES THAT THE BUYER OR USER ALONE HAS DETERMINED THAT THE PRODUCTS WILL SUITABLY MEET THE REQUIREMENTS OF THEIR INTENDED USE. OMRON DISCLAIMS ALL OTHER WARRANTIES, EXPRESS OR IMPLIED.

LIMITATIONS OF LIABILITY

OMRON SHALL NOT BE RESPONSIBLE FOR SPECIAL, INDIRECT, OR CONSEQUENTIAL DAMAGES, LOSS OF PROFITS, OR COMMERCIAL LOSS IN ANY WAY CONNECTED WITH THE PRODUCTS, WHETHER SUCH CLAIM IS BASED ON CONTRACT, WARRANTY, NEGLIGENCE, OR STRICT LIABILITY.

In no event shall responsibility of OMRON for any act exceed the individual price of the product on which liability is asserted.

IN NO EVENT SHALL OMRON BE RESPONSIBLE FOR WARRANTY, REPAIR, OR OTHER CLAIMS REGARDING THE PRODUCTS UNLESS OMRON'S ANALYSIS CONFIRMS THAT THE PRODUCTS WERE PROPERLY HANDLED, STORED, INSTALLED, AND MAINTAINED AND NOT SUBJECT TO CONTAMINATION, ABUSE, MISUSE, OR INAPPROPRIATE MODIFICATION OR REPAIR.

Application Considerations

SUITABILITY FOR USE

OMRON shall not be responsible for conformity with any standards, codes, or regulations that apply to the combination of products in the customer's application or use of the product.

At the customer's request, OMRON will provide applicable third party certification documents identifying ratings and limitations of use that apply to the products. This information by itself is not sufficient for a complete determination of the suitability of the products in combination with the end product, machine, system, or other application or use.

The following are some examples of applications for which particular attention must be given. This is not intended to be an exhaustive list of all possible uses of the products, nor is it intended to imply that the uses listed may be suitable for the products:

- Outdoor use, uses involving potential chemical contamination or electrical interference, or conditions or uses not described in this catalog.
- Nuclear energy control systems, combustion systems, railroad systems, aviation systems, medical equipment, amusement machines, vehicles, safety equipment, and installations subject to separate industry or government regulations.
- Systems, machines, and equipment that could present a risk to life or property.

Please know and observe all prohibitions of use applicable to the products.

NEVER USE THE PRODUCTS FOR AN APPLICATION INVOLVING SERIOUS RISK TO LIFE OR PROPERTY WITHOUT ENSURING THAT THE SYSTEM AS A WHOLE HAS BEEN DESIGNED TO ADDRESS THE RISKS, AND THAT THE OMRON PRODUCT IS PROPERLY RATED AND INSTALLED FOR THE INTENDED USE WITHIN THE OVERALL EQUIPMENT OR SYSTEM.

Disclaimers

CHANGE IN SPECIFICATIONS

Product specifications and accessories may be changed at any time based on improvements and other reasons.

It is our practice to change model numbers when published ratings or features are changed, or when significant construction changes are made. However, some specifications of the product may be changed without any notice. When in doubt, special model numbers may be assigned to fix or establish key specifications for your application on your request. Please consult with your OMRON representative at any time to confirm actual specifications of purchased product.

DIMENSIONS AND WEIGHTS

Dimensions and weights are nominal and are not to be used for manufacturing purposes, even when tolerances are shown.

ERRORS AND OMISSIONS

The information in this catalog has been carefully checked and is believed to be accurate; however, no responsibility is assumed for clerical, typographical, or proofreading errors, or omissions.

PERFORMANCE DATA

Performance data given in this catalog is provided as a guide for the user in determining suitability and does not constitute a warranty. It may represent the result of OMRON's test conditions, and the users must correlate it to actual application requirements. Actual performance is subject to the OMRON Warranty and Limitations of Liability.

PROGRAMMABLE PRODUCTS

OMRON shall not be responsible for the user's programming of a programmable product, or any consequence thereof.

COPYRIGHT AND COPY PERMISSION

This catalog shall not be copied for sales or promotions without permission.

This catalog is protected by copyright and is intended solely for use in conjunction with the product. Please notify us before copying or reproducing this catalog in any manner, for any other purpose. If copying or transmitting this catalog to another, please copy or transmit it in its entirety.