

Subminiature Time Totalizers Require No External Power Supply

- Subminiature 48 x 24 mm (1.89 x .94 in)
- Improved noise immunity
- Screw terminal and wire-wrap types available
- Printed circuit board version (H7EQ-P)
- AC, DC, and no-voltage input
- Panel adapters for existing cutouts (order separately from accessories)
- Self-powered, 3 V lithium battery



Ordering Information

■ TIME TOTALIZERS

Operating mode		UP type				
Display		LCD digital, 5.1 mm (0.2 in) high				
Reset system		See note below				
Type of input		AC/DC voltage input	DC voltage input		No voltage input	
Terminals		Screw	Wire-wrap	Screw	Wire-wrap	Screw
Time range (Number of digits)	0.0 to 99999.9 h (6 digits)	—	H7ET-VM	H7ET-BVM	H7ET-M	H7ET-BM
	0.0 to 999999.9 h (7 digits)	H7ET-FBV	H7ET-V	H7ET-BV	H7ET	H7ET-B
	0.0 to 99 h 59 m 59.9 s (7 digits)	H7ET-FBV1	—	H7ET-BV1	—	H7ET-B1
	0.0 to 9999 h 59.9 m (7 digits)	H7ET-FBV2	—	H7ET-BV2	—	H7ET-B2
	0.0 to 3999 d 23.9 h (7 digits)	H7ET-FBV3	—	H7ET-BV3	—	H7ET-B3

Note: Models with the -M suffix are provided with both manual and external (electrical) resetting features. Models without the -M suffix are provided with external reset terminals.

■ ACCESSORIES

Description		Part number
Panel adapters	Fits 26 x 45 mm (1.02 x 1.77 in.) rectangular cutout	Y92F-75
	Fits 27.5 x 52.5 mm (1.1 x 2.07 in.) rectangular cutout	Y92F-76
	Fits 24.8 x 48.8 mm (0.98 x 1.92 in.) rectangular cutout	Y92F-77

Specifications

■ RATINGS

Supply voltage	Not required (powered by built-in battery)
Input	AC/DC voltage input: 24 to 240 VAC \pm 10%, 50/60 Hz, or 6 to 240 VDC \pm 10% at "High" (logic) level 0 to 1.5 VAC \pm 10%, 50/60 Hz, or 0 to 2 VDC \pm 10% at "Low" (logic) level DC voltage input: 4.5 to 30 VDC at "High" (logic) level 0 to 2 VDC at "Low" (logic) level No-voltage input: Maximum short-circuit impedance: 10 k Ω max. Short-circuit residual voltage: 0.5 V max. Minimum open impedance: 500 k Ω min.
Reset time	External and manual reset types (6-digit models): 20 ms reset signal External reset types (7-digit models): 20 ms reset signal

* ON/OFF ratio 1:1

Approved by the following standards

UL

CSA

CE (EMC)

■ CHARACTERISTICS

Insulation resistance	100 M Ω min. at 500 VDC
Dielectric strength	1,000 VAC 50/60 Hz for 1 minute between current-carrying terminals and exposed non-current-carrying metal parts
Vibration	Mechanical durability: 10 to 55 Hz; 0.75 mm (0.03 in) double amplitude Malfunction durability: 10 to 55 Hz; 0.3 mm (0.02 in) double amplitude
Shock	Mechanical durability: Approx. 30 G Malfunction durability: Approx. 10 G
Ambient temperature	Operating: -10° to 55°C (14° to 131°F) Storage: -25° to 65°C (-13° to 149°F)
Humidity	Operating: 35 to 85% RH
Battery life	10 years min. of continuous operation
Weight	AC/DC voltage input type: Approx. 90 g (3.18 oz) including mounting bracket DC voltage and No-voltage input types: Approx. 60 g (2.12 oz) including mounting bracket

Timing Chart

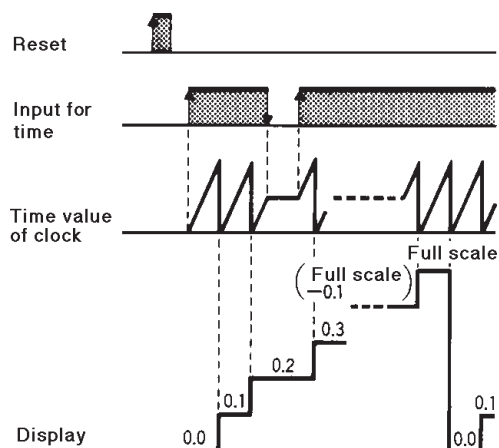

Dimensions

Unit: mm(inch)

■ SCREW TERMINAL COUNTERS

No-voltage and DC Input Types

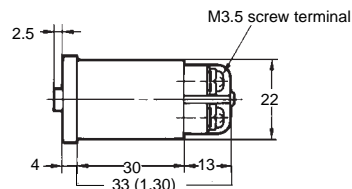
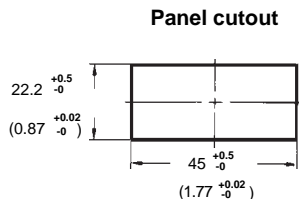
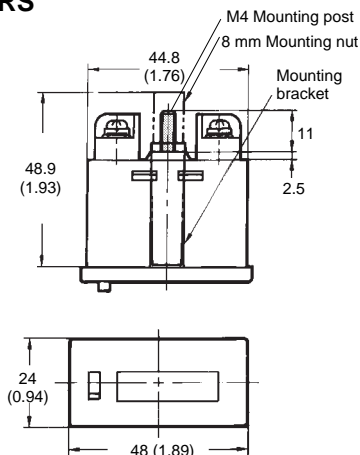
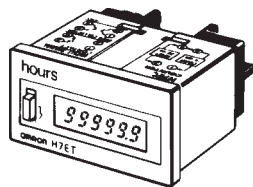

AC/DC Voltage Input Type

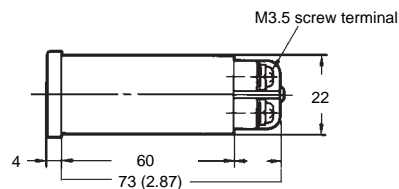
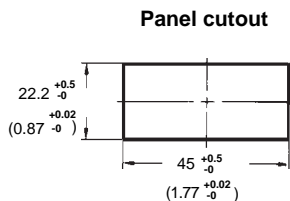
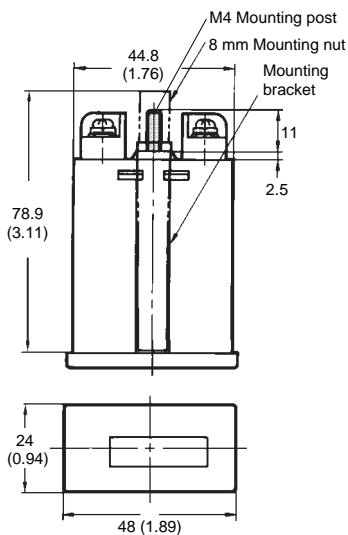
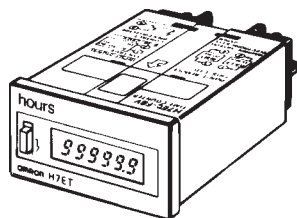

■ WIRE-WRAP TERMINAL COUNTERS

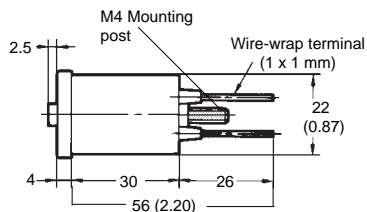
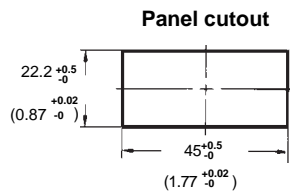
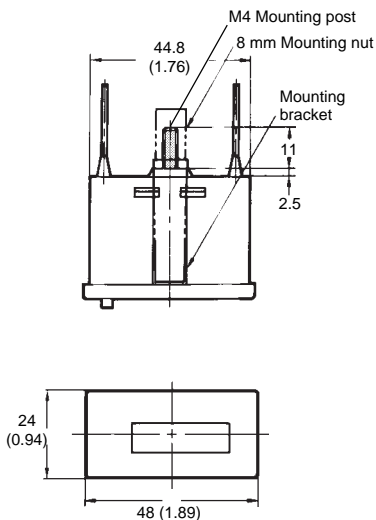
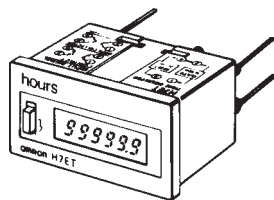

Mounting holes and footprint

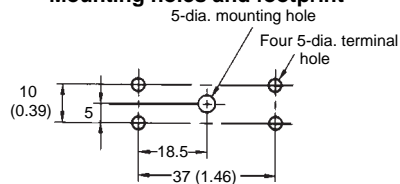

■ PANEL MOUNTING ADAPTERS

Y92F-75

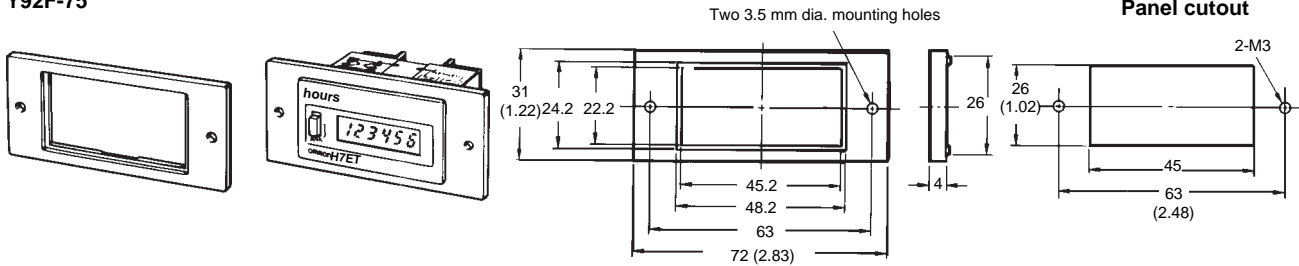

Y92F-76

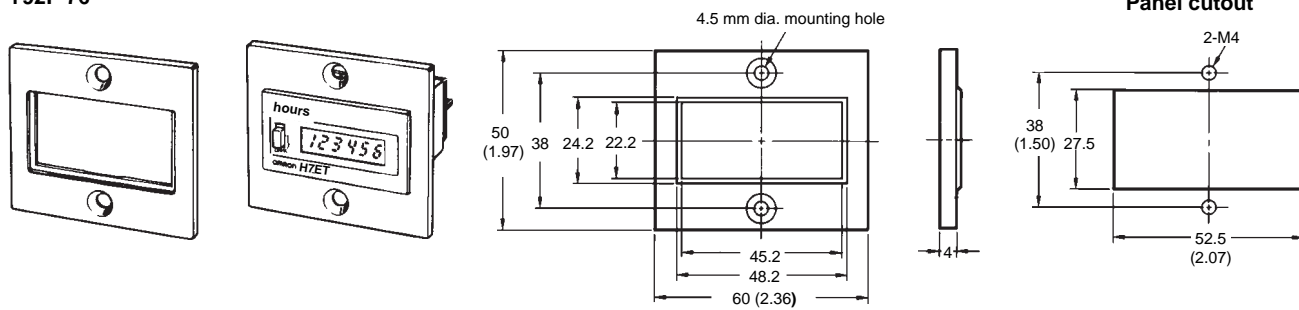

Y92F-77

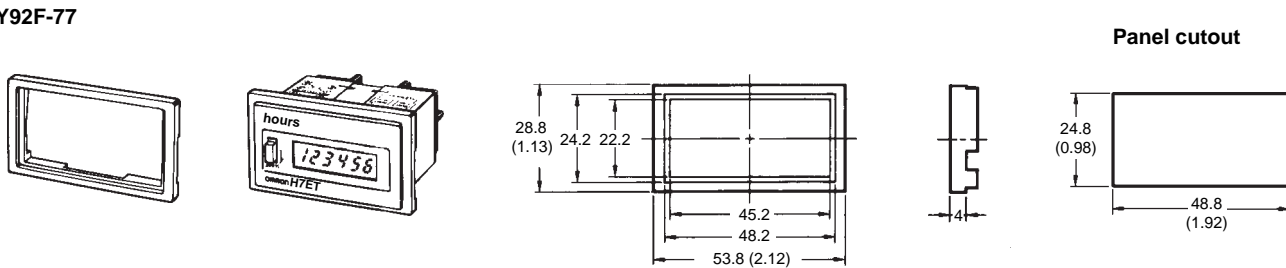

Connections

■ AC/DC VOLTAGE INPUT TYPE

1. Contact input (voltage input through a relay or switch contact)
2. Solid-state input (open collector input of an NPN transistor)

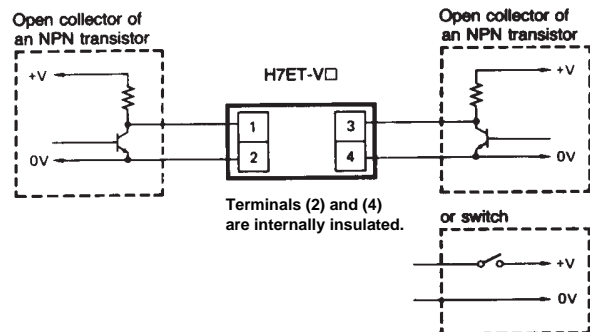
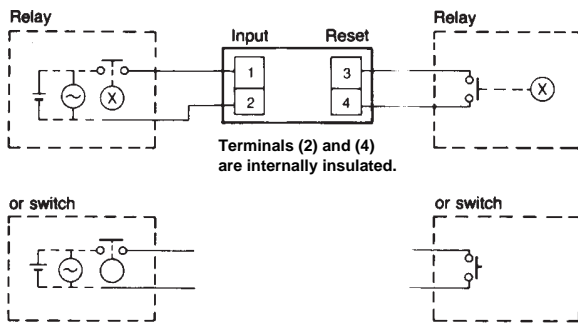

■ DC VOLTAGE INPUT TYPE

1. Contact input (voltage input through a relay or switch contact)

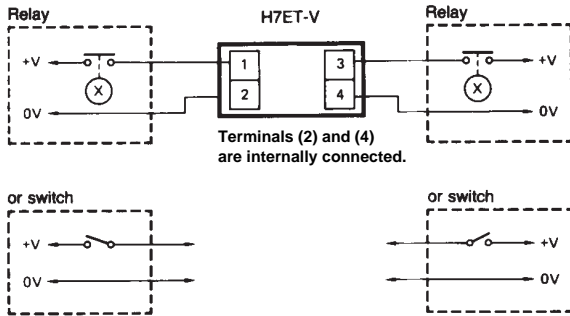

2. Solid-state input (open collector input of an NPN transistor)

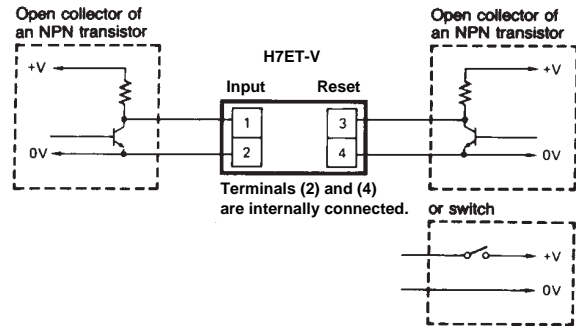

■ NO-VOLTAGE INPUT TYPE

1. Contact input (input by a relay or switch contact)

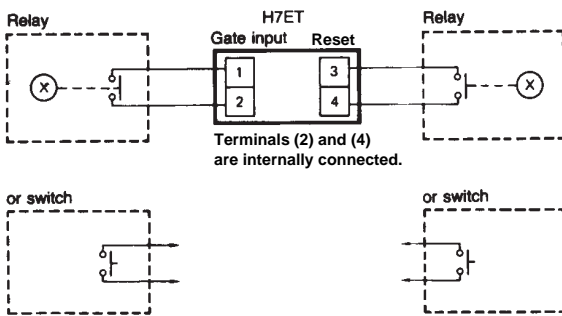

2. Solid-state input (open collector input of an NPN transistor)

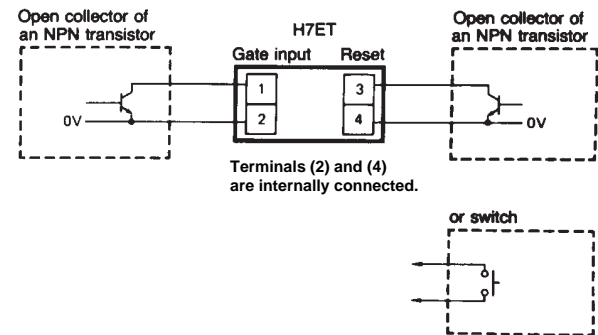

Operations

■ SELECTING THE H7ET TOTALIZING COUNTER

Determine the maximum counting speed of the counter by evaluating the input conditions listed in the table at right.

Counting speed	20 or 30 cps	1 kcps
Contact signal input	Relay or switch contact input with some chattering.	Do not input contact signal inputs. Chattering is counted as signal input.
Solid-state signal input	Low-speed transistor inputs	High-speed transistor inputs

■ INPUT VERIFICATION WITH THE H7ET TIME COUNTER

The decimal point on models with 0.1 hour and 0.1 minute displays blinks every other second while an input signal is being applied. If the decimal point is not blinking, the input signal is not being received correctly. Check the input signal connections.

For models with 0.1 second displays, the decimal point does not blink. The input signal causes the right-most digit to increment frequently enough to observe whether or not the input signal is being received correctly. If the display does not increment, the input signal is not being received.

Installation

MANUALLY RESETTING COUNTERS (-M SUFFIX MODELS)

Counters with "-M" suffixes offer the option of manual or external resetting. To manually reset the counter, press the reset button located to the left of the display window. To prevent an accidental reset, lock the reset button by sliding the button downward, without depressing it. A small "click" sound may be heard, both when locking and unlocking the reset button. Slide the button up to unlock.

hours

H7ET

WIRE-WRAP TERMINALS

The terminals used on H7E wire-wrap models have a cross sectional dimension of 1 x 1 mm. Select one of the three gauges of wire from the table at right. Also listed in the table are the appropriate wiring hardware.

Wire gauge	Bit	Sleeve	Method
AWG22	2-A	2-B	Normal wire-wrap
AWG24	1-A	1-B	Normal wire-wrap
AWG26	3-A	3-B	Normal wire-wrap

CAUTIONS CONCERNING THE H7ET TIME COUNTER

On some H7E models, the power input terminal and the common signal input terminal (terminals 2 and 4) are internally short-circuited. Pay special attention to polarity when wiring these terminals.

Keep the input wiring as short as possible.

Whenever possible, avoid routing the input wiring of the AC/DC voltage input type in parallel with 200 to 240 VAC power lines.

If the input wiring must be routed together with the power lines, keep the length of that portion of wire running parallel with the power lines to within 20 m (65.6 feet).

When using shielded wire, stray capacitance may occur. The operation of the counter might be affected when using wires which have a capacitance which exceeds 500 pF (about 10 m, 32.8 feet, with parallel wires of 2 mm²). Keep all wires as short as possible.

HOW TO MOUNT THE COUNTER

Insert the H7E counter from the front of the mounting panel. Slide the mounting bracket into place from the rear of the panel, and tighten the knurled nut by hand. Do not use tools (such as pliers) to tighten the nut. Excessive tightening may damage the counter. Wire-wrap terminal models may be back-mounted, by soldering the terminals to a printed circuit board.

NOTE: DIMENSIONS SHOWN ARE IN MILLIMETERS. To convert millimeters to inches, divide by 25.4.

Omron Europe B.V. EMA-ISD, tel:+31 23 5681390, fax:+31 23 5681397, <http://www.eu.omron.com/ema>